

Signal S500 SERIES

www.signal-pumps.co.uk

S500 PM-K Electromagnetic metering pump

An economic electromagnetic metering pump, ranging up to 20lt/hr, suitable for a diverse range of chemical dosing applications.

Designed for wall or backboard mounting.

- LED power-on
- LED pulse solenoid
- Knob for flow rate percentage adjustment
- Double range regulation
- Keys max frequency selection (100% or 20%)
- Start and Stop Keys
- Plastic box IP65 protection degree



Signal
METERING PUMPS

A division of GEE & Co

TECHNICAL DATA

S500 SERIES - PM-K Electromagnetic metering pump

Models	PM 02-10	PM 05-07	PM 08-10	PM 20-03
Flow rate max (l/h)	2	5	8	20
Pressure max (bar)	10	7	10	3
Frequency max (imp/min)	100	100	120	120
ml/pulse	0,33	0,83	1,11	2,60
Max suction high (m)	2.0	2.0	2.0	2.0
Standard power supply (*)	230 V - 50/60 Hz	230 V - 50/60 Hz	230 V - 50/60 Hz	230 V - 50/60 Hz
Weight (kg)	2,3	2,3	2,9	2,9

(*Power Supply: Standard 230 Vac 50/60 Hz. On request - 110 Vac, 24 Vac, 24 Vdc, 12V.)

Dimensions

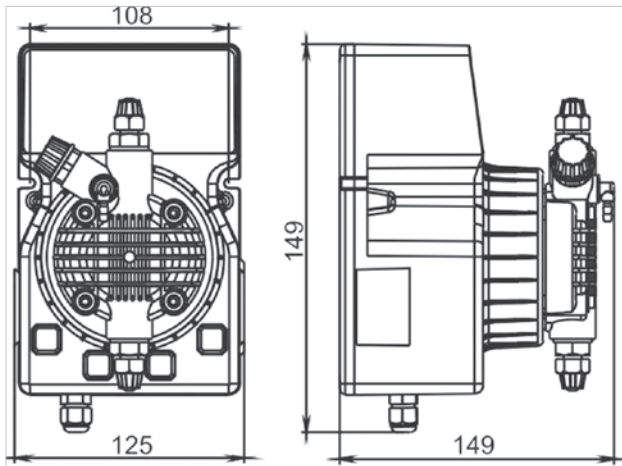

Materials:

Pump head: polypropylene
(on request: PVC, SS316, PTFE, PVDF)

Diaphragm: PTFE

Connections: polypropylene

Foot filter: polypropylene

Injection valve: polypropylene

Suction tube: PVC crystal

Delivery tube: polyethylene

Lip valves (standard): FPM
(on request: silicon, EPDM, NBR)

Ball valves (on request): Pyrex,
Kalretz, SS316

Seat: FPM (on request: silicon, EPDM,
PTFE, NBR)



Signal Metering Pumps, Gee House, Holborn Hill, Birmingham B7 5JR
Tel: 0121 326 1700 Fax: 0121 326 1779 Email: info@signal-pumps.co.uk Web: www.signal-pumps.co.uk

A division of GEE & Co